

ST Series

Domestic Hot Water Storage Tanks



HP Models



NC Models



DW Models

Introducing the Tunstall Industries ST Series domestic hot water storage vessels. Made from stainless steel using high quality manufacturing techniques, our tanks do not require a lining or a sacrificial anode to protect against corrosion. The vessels are well insulated to reduce heat loss, and are fully recyclable to reduce the embodied carbon impact. The quality of the Tunstall ST Series is backed by a 10-year commercial warranty that's twice as long as the competition, and available at a competitive price.

- ✓ 316L stainless steel tank
- ✓ 10-year commercial tank warranty
- ✓ Pickled & passivated for superior longevity and corrosion resistance
- ✓ Fully welded
- ✓ No anode required
- ✓ H/CFC-free 2.5" polyurethane (PU) foam insulation layer (R-16.5)
- ✓ Insulated to exceed ASHRAE 90.1
- ✓ Powder coated steel jacket
- ✓ Customizable fittings upon request
- ✓ 150 PSI operating pressure rating
- ✓ Includes ASME T&P relief valve rated to 500,000 BTU/hr



Stratified Storage Tanks with Diffuser (HP Models)

Tank fittings configured & sized for stratified heat pump water heating applications, accommodating single-pass piping design.

- ✓ Inlet calming diffuser maximizes usable storage volume and promotes stratification layer required for single-pass heat pump arrangements
- ✓ Commercial sized inlet & outlet at 2" NPT reduces pressure drop for higher demand applications
- ✓ Low, mid and high level multipurpose fittings at 1" NPT can be used for temperature thermowells, aquastat control, recirculation return, or circulation input from external multi-pass heat source

Heat Input Options:

- ✓ Heat pump water heaters
- ✓ Tankless water heaters
- ✓ District energy systems
- ✓ External HX with single pass flow control



10-year commercial warranty

Stratified Storage Tanks

HP Models

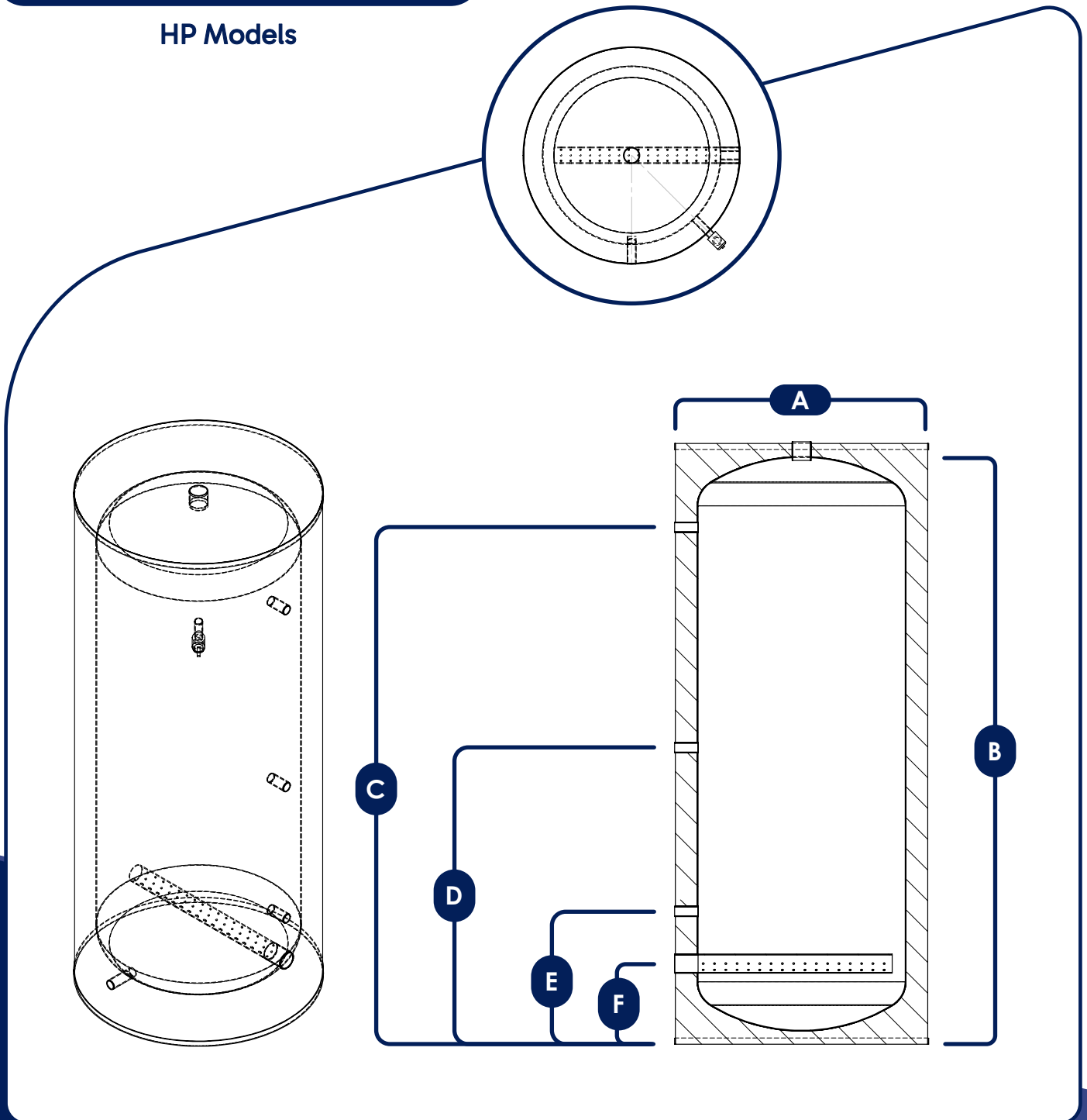

Model	Capacity	Inlet & Outlet	Multipurpose Fittings	Dimensions (inches)						Dry Weight	Operating Weight
				A	B	C	D	E	F		
ST80-HP	80 gal	2" FNPT	1" FNPT	25.0	64.3	54.3	31.8	15.75	9.75	290 lbs	960 lbs
ST120-HP	119 gal	2" FNPT	1" FNPT	29.0	69.0	59.4	34.0	15.25	9.25	370 lbs	1370 lbs

Standard Storage Tanks (NC Models)

Typical DHW storage tank connections including circulating fittings for external energy input from multi-pass heat source.

- ✓ 2" NPT circulating fittings for heat input from external source
- ✓ Control sensor fitting at mid tank level
- ✓ Aquastat included for enabling remote energy input

Heat Input Options:

- ✓ Hydronic heating system (via external HX)
- ✓ Multi-pass heat pump water heaters
- ✓ Tankless gas or electric water heaters
- ✓ Solar thermal or geo thermal



10-year commercial warranty

Standard Storage Tanks

NC Models

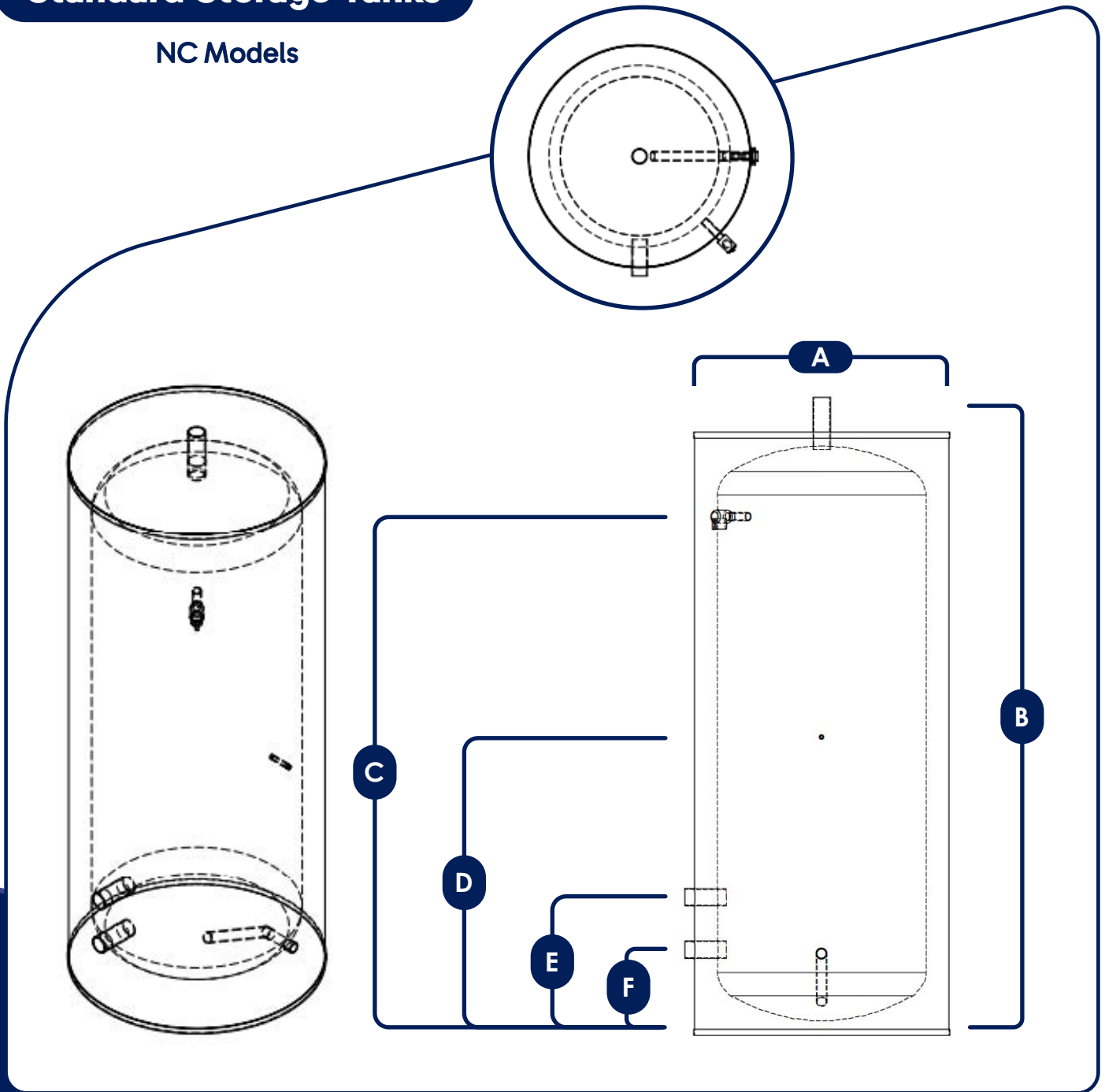

Model	Capacity	Cold Inlet	Hot Outlet	Dimensions (inches)						Dry Weight	Operating Weight
				A	B	C	D	E	F		
ST40-NC	40 gal	3/4" MNPT	3/4" MNPT	23	41	32	21	14.25	8.25	175 lbs	508 lbs
ST60-NC	60 gal	3/4" MNPT	3/4" MNPT	21	60	52	28	14.25	8.25	207 lbs	707 lbs
ST80-NC	80 gal	1" MNPT	1" MNPT	23	63.3	54.25	32.25	15.75	9.75	240 lbs	906 lbs
ST120-NC	119 gal	1.25" MNPT	2" MNPT	29	69.4	59.3	34	15.75	9.75	300 lbs	1291 lbs

Double Wall Coil Tanks (DW Models)

Indirect water heaters with internal heat exchanger coil for energy input via hydronic heat source.

- ✓ Double wall coil with visible leak detection meets commercial building code requirements
- ✓ Ensures hydronic source water doesn't contaminate potable water in the event of a leak in the heat exchanger
- ✓ Extra long 40' coil offers 14.4 square feet of heating surface area

Heat Input Options:

- ✓ Hydronic heating loop (direct input to coil)
- ✓ Gas or electric boilers
- ✓ High temperature heat pumps
- ✓ Heat recovery / pre-heat applications



10-year commercial warranty

Double Wall Coil Tanks

DW Models

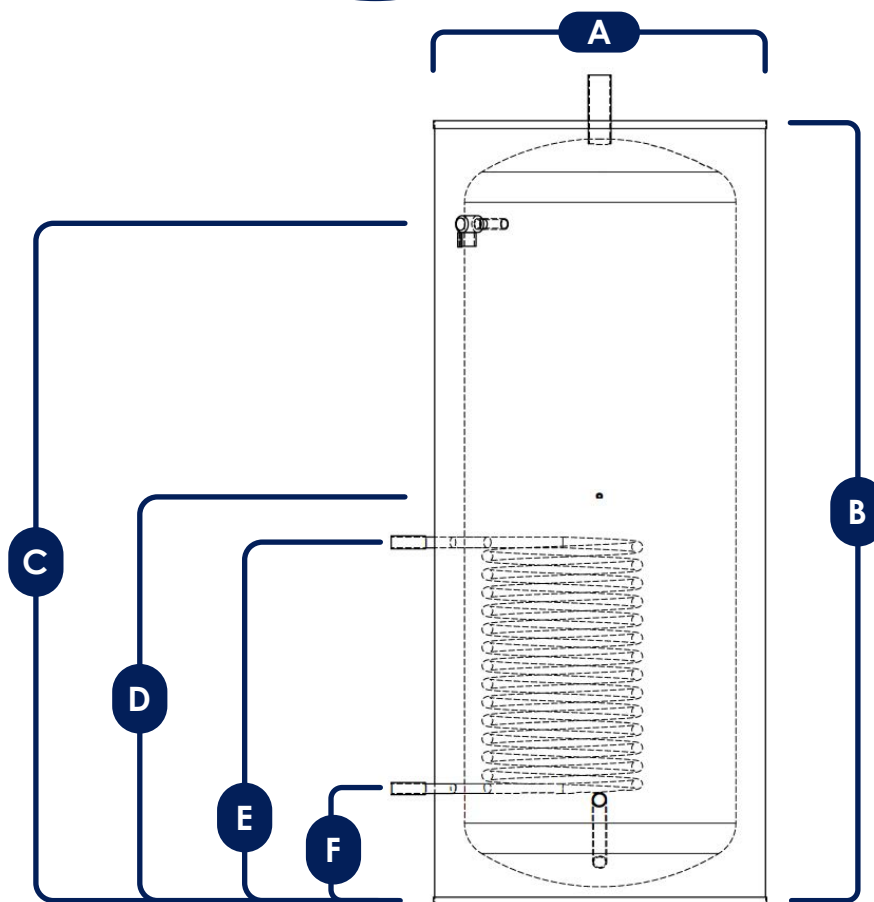
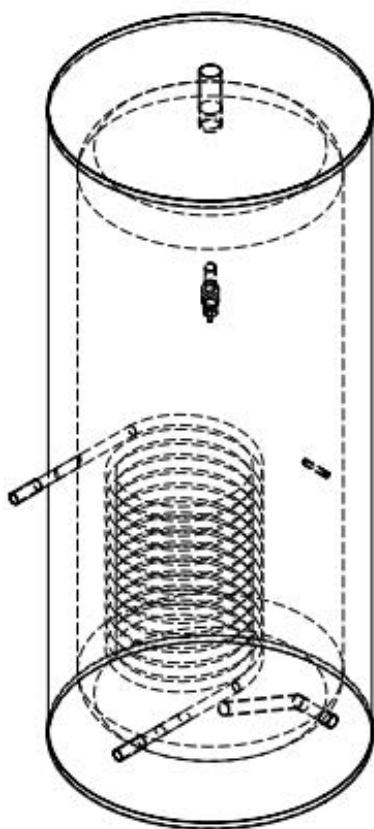
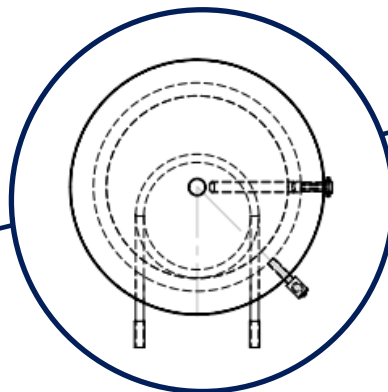

Model	Capacity	Cold Inlet	Hot Outlet	Dimensions (inches)						Dry Weight	Operating Weight
				A	B	C	D	E	F		
ST80-DW	80 gal	1" MNPT	1" MNPT	25	64.9	54.25	36.25	33.25	10.75	290 lbs	956 lbs
ST120-DW	119 gal	1.25" MNPT	2" MNPT	29	68.38	59.31	36	32.75	10.25	370 lbs	1361 lbs

- ◆ 112,900 BTU/hr input
- ◆ 135 GPH recovery @ 100°F DHW temperature rise
- ◆ 169 GPH recovery @ 80°F DHW temperature rise
- ◆ 3 PSI coil pressure drop at 20 GPM flow rate